

Provided for non-commercial research and educational use only.  
Not for reproduction or distribution or commercial use.

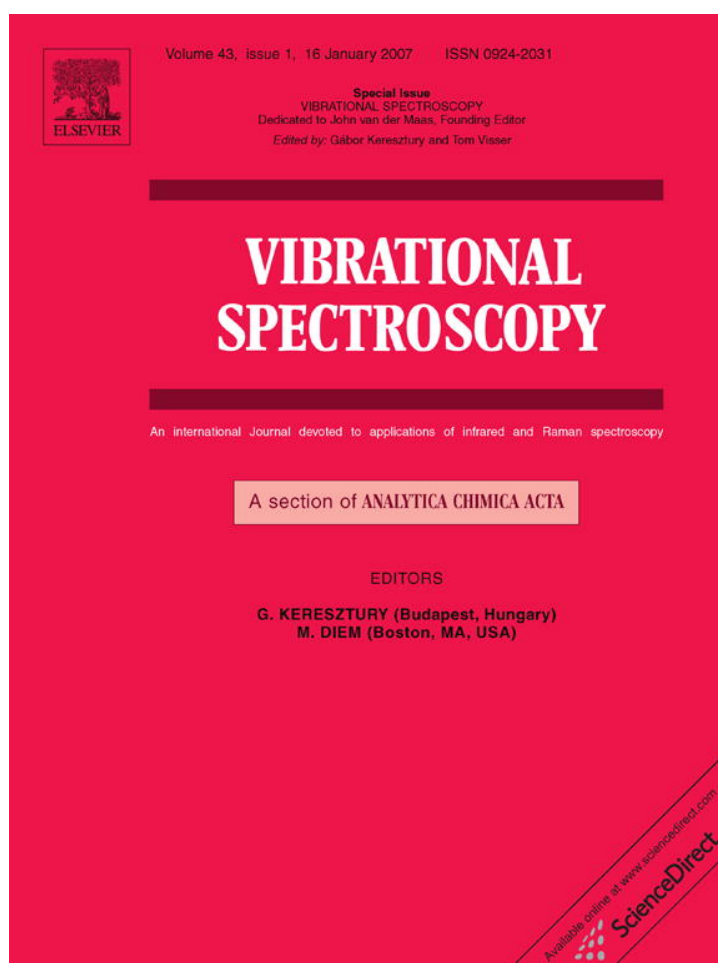

This article was originally published in a journal published by Elsevier, and the attached copy is provided by Elsevier for the author's benefit and for the benefit of the author's institution, for non-commercial research and educational use including without limitation use in instruction at your institution, sending it to specific colleagues that you know, and providing a copy to your institution's administrator.

All other uses, reproduction and distribution, including without limitation commercial reprints, selling or licensing copies or access, or posting on open internet sites, your personal or institution's website or repository, are prohibited. For exceptions, permission may be sought for such use through Elsevier's permissions site at:

<http://www.elsevier.com/locate/permissionusematerial>

## Asymmetric static Fourier-spectrometer for solid surfaces and nano-films study

A.A. Balashov<sup>a</sup>, G.D. Bogomolov<sup>b</sup>, A.P. Kiryanov<sup>a</sup>, A.K. Nikitin<sup>a</sup>,  
V.I. Pustovoi<sup>a</sup>, V.A. Vaguin<sup>a</sup>, G.N. Zhizhin<sup>a,\*</sup>

<sup>a</sup> *Scientific and Technological Centre for Unique Instrumentation, Russian Academy of Science,  
Butlerova St. 15, 117342 Moscow, Russia*

<sup>b</sup> *Institute for Physical Problems, Russian Academy of Science, Kosygina St. 2, 117973 Moscow, Russia*

Received 6 June 2006; received in revised form 19 June 2006; accepted 19 June 2006

Available online 27 July 2006

### Abstract

The optical scheme and functioning of a static Fourier-transform (FT) spectrometer employing surface electromagnetic waves (SEW) is discussed. SEW are excited by the probing radiation on the sample placed in one shoulder of the asymmetric interferometer. Interference pattern (interferogram) carrying information about the surface is registered by the detector array, disposed on the ellipse surface. This way of detectors positioning leads to linearization of the phase shift function on the pixels coordinates projection on the ellipse large axis. There are no moving parts in the instrument. That is why it can work as “one pulse spectrometer”. The length of SEW path determines the limiting spectral resolution, while time resolution depends on detector characteristics. The spectrometer provides the possibility of obtaining not only absorption (emission) spectra, but the spectra of complex refractive index as well.

© 2006 Elsevier B.V. All rights reserved.

**Keywords:** Fourier-transform spectrometry; Surface electromagnetic waves; Time-domain spectroscopy; Complex refractive index; Static interferometer

Processes with duration of parts of a second can now be easily studied using “step-scanning” FT-spectrometers. The creation of lasers generating ultra short pulses challenged the “pump-probe” surface experiments with surface chemical reactions, for example, the pump with ps-pulse and the probe of 1 fs. It is clear that probing interferometer should be of “static” type able to make measurements in extra short time interval with on line data saving.

Three important peculiarities are put into the foundation of the discussed Fourier-spectrometer optical scheme which enables one to obtain optical constants spectra of smooth metal surfaces as well as those of super thin (up to nm thick) metal films on metal, semiconductor or dielectric substrates. These words pertain equally to dielectric nm-films formed on metal substrates due to chemical reactions or by the well-known techniques for creating thin-film coverage as Langmuir–Blodgett method, vacuum evaporation and the like.

The first peculiarity is the asymmetry of the interferometer, which implies the sample’s accommodation in one of its shoulders. This way of measurements performance makes possible to determine the refractive index  $n(\nu)$  and the absorption index  $k(\nu)$  spectra independently in a wide frequency spectral range by using sine and cosine Fourier transformations as soon as the interferogram is registered [1].

The second peculiarity lies in the fact that along with bulk electromagnetic waves surface electromagnetic waves (SEW) from the visible up to the millimeter ranges are used in the interferometer.

The third peculiarity is that the interferometer can be classified as a static one [2,3] as it has no moving parts; there is no need to scan the optical path difference because the interferogram is localized in space.

The interferogram is registered and discretized by a photodetector array positioned on the elliptic cylinder surface or, more precisely, on the line of intersection of the cylinder with the plane of light incidence (Fig. 1). In case the interferometer is assembled along with the suggested scheme its action-time is determined by the radiation detectors

\* Corresponding author. Tel.: +7 495 333 50 81; fax: +7 495 334 75 00.  
E-mail address: [gzhizhin@mail.ru](mailto:gzhizhin@mail.ru) (G.N. Zhizhin).

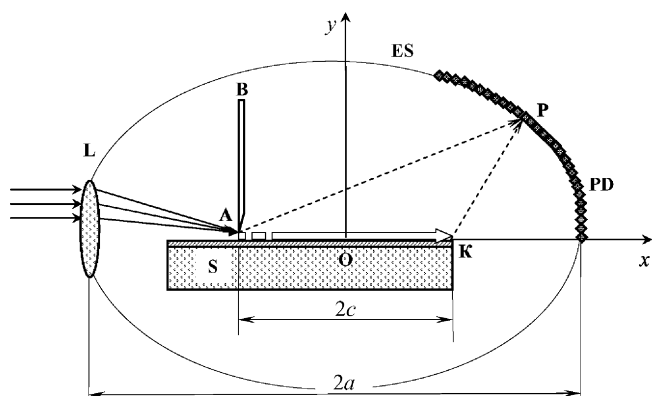

Fig. 1. Optical scheme of the proposed asymmetric static Fourier-spectrometer.

characteristics exclusively; in particular it may be used as “a single-pulse spectrometer” to analyze spectrum of synchrotron radiation or that of electron bunch in free-electron lasers (FEL).

The idea to develop an asymmetric static Fourier-spectrometer (ASFS) was created by our team as a result of long-standing experiments with such modifications of SEW as surface plasmon-polaritons [4–7] and phonon-polaritons [8,9] as well as in process of performing investigations on surface properties of metals, dielectrics and their transition layers. As elementary excitations of these solids fall in different spectral ranges we had to use lasers generating from the visible to submillimeter bands (visible and near infrared (IR) ranges [10], middle IR [11–13], submillimeter range [14,15]).

Up to the present we used the monochromatic regime to determine sample’s values of  $n$  and  $k$  by the method of FEL SEW-spectroscopy which implies interferometric measurements at not less than two different distances covered by SEW. In this case interferogram has much in common with the sine curve and its execution is rather simple [14,15].

Frequency change in this regime is reminiscent of the classic scanning monochromator operation related with all its drawbacks, specifically Fellgett gain loss [16,17]. But if the radiation source has a broad spectrum, like a synchrotron or FEL with pulse duration of about 1 fs, one has to use ASFS to find out the spectrum. For instance for FEL pulses with duration of 1 fs their Fourier spectrum has width of about  $3000 \text{ cm}^{-1}$  and the pulses, “colored” in frequency of  $1500 \text{ cm}^{-1}$  (wavelength  $6 \mu\text{m}$ ) the spectrum spreads from 1 to  $3000 \text{ cm}^{-1}$ , that is it will cover whole IR and terahertz bands with wavelength larger than  $3 \mu\text{m}$ .

In all our experiments with monochromatic radiation sample was incorporated in one of the interferometer shoulders and the sample was probed by the radiation existing in the form of SEW excited by the aperture method using an ordinary razor blade A (see Fig. 1) [18]. On arriving to the sample’s edge K SEW is converted in a bulk wave due to diffraction on the edge. The points A and K, spaced from the point of observation P by distances  $r_1$  and  $r_2$ , represent themselves poles of the ellipse satisfying the equation  $r_1 + r_2 = 2a$  (here  $2a$  is the ellipse main axis length). Photodetector positioning on the elliptic curve simplifies the description of phase relations between the interfering light beams.

Optical scheme of the static Fourier-spectrometer [2–7], implementing the asymmetric version of Fourier-spectroscopy [1], is presented in Fig. 1. The radiation under study is focused by the objective lens L on the input aperture A, representing itself a slit formed by the razor blade B and the sample surface S. Afterwards it diffracts on the slit and is partially radiated in the form of a bulk electromagnetic wave (BEW) propagating forward in the direction of the point P in the limits of radiation diagram and the rest of incident radiation is coupled into SEW, running along the sample surface S in  $x$ -direction up to its edge K. Here, due to diffraction on the edge K, SEW is converted in BEW propagating ahead to the point P as well in the limits of its own radiation diagram. Both coherent BEW, emitted from points A and K, interfere at the point P, located on the ellipse surface (ES), and form in this way an interference pattern (interferogram) spreading over the whole ES above the sample. The interferogram is registered by the photodetector array PD, residing on ES in the plane of incidence.

The interference signal  $I_p(\nu)$  measured by the detector with coordinate  $x$  is described by the following relation [19,20]:

$$I_p(\nu) = I_{01}(\nu) \left\{ 1 + [\gamma(\nu)]^2 \exp \left[ \frac{-8\pi k(\nu) c \nu}{v} \right] + 2\gamma(\nu) \exp \left[ \frac{-8\pi k(\nu) c \nu}{v} \right] \cos \psi(\nu) \right\},$$

here

$$\psi(\nu) = \left( \frac{2\pi c \nu}{a v} \right) x + \left( \frac{2\pi n(\nu) c \nu}{v} \right) + \varphi(\nu)_{12}; \quad (1)$$

$I_{01}(\nu)$  is the intensity of the radiation produced by the source at point A,  $\gamma(\nu) = \sqrt{I_{02}(\nu)/I_{01}(\nu)}$  the intensities relation of BEW, radiated from points A and K,  $v$  speed of electromagnetic waves in vacuum;  $c$  the half of the distance between the ellipse focuses,  $\varphi(\nu)_{12}$  is the phase additive, regarding the phase difference of the two BEW due to phase shifts caused by the input aperture A and the sample edge K.

Signal  $I_p$  registered by the detector placed at an arbitrary point P represents itself the sum of contributions  $I_p(\nu)$  of all components of radiation with frequency  $\nu$ :

$$I_p = \int I_p(\nu) \frac{d\nu}{\Delta\nu},$$

where  $\Delta\nu$  is the radiation spectral range.

On the other hand signal  $I_p$  consists of the interference signal  $I_{p\text{int}}$  and the background signal  $I_{p\infty}$ :

$$I_p = I_{p\text{int}} + I_{p\infty},$$

here the additive  $I_{p\infty} = \int I_{01}(\nu) \{ 1 + [\gamma(\nu)]^2 \exp[-8\pi k(\nu) c \nu / v] \} d\nu / \Delta\nu$ , represents itself the signal got at very large phase shifts ( $\psi \rightarrow \infty$ ), when visibility of the interference pattern practically vanishes;

$$I_{p\text{int}} = \frac{\int R(\nu) \cos \psi d\nu}{\Delta\nu}, \quad (2)$$

here  $R(\nu) = 2I_{01}(\nu) a(\nu) \exp\{-8\pi k(\nu) c \nu / v\}$ .

Making use of trigonometric relations and formula (1) one can present the integral expression (2) like this:

$$I_{\text{pint}} = \int \left[ C(\nu) \cos\left(\frac{2\pi c\nu x}{av}\right) + S(\nu) \sin\left(\frac{2\pi c\nu x}{av}\right) \right] \frac{dv}{\Delta\nu}, \quad (3)$$

here

$$C(\nu) = R(\nu) \cos\left\{ \left[ \frac{2\pi n(\nu)c\nu}{v} \right] + \varphi(\nu)_{12} \right\},$$

$$S(\nu) = R(\nu) \sin\left\{ \left[ \frac{2\pi n(\nu)c\nu}{v} \right] + \varphi(\nu)_{12} \right\}.$$

It is worth noting that owing to placing the photodetector line on the ellipse curve the phase argument  $\varphi(x) = (2\pi c\nu/Av)x$  of relation (3) is proportional to coordinate  $x$ , fitting the photodetector location projection on the axis  $x$ . As a result of this fact one can make integral sine and cosine Fourier transformations of the interferogram  $I_{\text{pint}}(x)$  registered by all photodetectors, in accordance with relation (3) and get sine and cosine spectral Fourier-images of the interferogram:

$$C(\nu) = \int I_{\text{pint}}(x) \cos\left(\frac{2\pi c\nu x}{av}\right) dx, \quad (4)$$

$$S(\nu) = \int I_{\text{pint}}(x) \sin\left(\frac{2\pi c\nu x}{av}\right) dx. \quad (5)$$

On doing this one can write the expression for the intensity spectrum:

$$I(\nu) = \sqrt{C(\nu)^2 + S(\nu)^2} \\ = 2\sqrt{I_{01}(\nu) \times I_{02}(\nu)} \exp\left[\frac{-4\pi k(\nu)c\nu}{v}\right]$$

as well as the relation for sine and cosine spectral Fourier-images:

$$\frac{S(\nu)}{C(\nu)} = \text{tg}\left\{ \left[ \frac{2\pi n(\nu)c\nu}{v} \right] + \varphi(\nu)_{12} \right\},$$

which make it possible to determine the dependence  $n(\nu)$ .

Apparatus characteristics:  $\gamma(\nu) = \sqrt{I_{02}(\nu)/I_{01}(\nu)}$  and  $\varphi(\nu)_{12}$  can be determined by preliminary measurements using the geometry of the static asymmetric Fourier-spectrometer and monochromatic radiation.

Spectrum of the registered signal  $S(\nu)$  and  $C(\nu)$ , like any other real spectrum, is limited by frequency  $\nu$  and satisfies the sampling theorem conditions [21]. According to this theorem the integrals in formulae (4) and (5) could be replaced by discrete sums under the condition that if we take values of the interferogram  $I_i$  in discrete points of readings  $x_i = iD$  spaced from one another by distance  $D$ , which is determined by the spectral interval  $\Delta\nu$ :

$$D = \frac{v}{4\pi\Delta\nu},$$

with the number of points  $N$  in the discrete spectrum  $\nu_j$  is equal to the number of registered points  $x_i$  in the interferogram  $I_i(x_i)$ , that is to the number of photodetectors in the array.

Finally one can get the following expressions:

$$C(\nu_j) = \sum I_i(x_i) \cos\left(\frac{2\pi c\nu_j \times i \times D}{av}\right),$$

$$S(\nu_j) = \sum I_i(x_i) \sin\left(\frac{2\pi c\nu_j \times i \times D}{av}\right),$$

$$I(\nu_j) = \{[C(\nu_j)]^2 + [S(\nu_j)]^2\}^{1/2},$$

$$\frac{S(\nu_j)}{C(\nu_j)} = \text{tg}\left\{ \left[ \frac{2\pi n(\nu_j)c\nu_j}{v} \right] + \varphi(\nu_j)_{12} \right\}.$$

To the best of our knowledge the asymmetric static interferometer of Fourier-spectrometer employing surface electromagnetic waves along with bulk ones has been discussed here for the first time.

## References

- [1] J.R. Birch, T.J. Parker, *Infrared Millimeter Waves 2* (1979) 137.
- [2] B.N. Grechushnikov, G.I. Distler, I.P. Petrov, XIII Meeting on spectroscopy, Thesis, Leningrad, 1960.
- [3] L.V. Egorova, D.S. Ermakov, D.G. Kuvalkin, O.K. Taganov, *J. Opt. Technol.* 2 (1992) 3.
- [4] G.N. Zhizhin, O.I. Kapusta, M.A. Moskaliyova, V.G. Nazin, V.A. Yakovlev, *Soviet Phys. Uspekhi* 117 (1975) 573.
- [5] G.N. Zhizhin, V.A. Yakovlev, *Vibr. Spectrosc.* 1 (1990) 235.
- [6] G.N. Zhizhin, D.M. Shkrabo, L.A. Kuzik, I.A. Garbuzova, *Vibr. Spectrosc.* 17 (1998) 155.
- [7] E.V. Alieva, L.A. Kuzik, V.A. Yakovlev, D.M. Shkrabo, G.N. Zhizhin, A.F.G. Van der Meer, M.J. Van der Wiel, *Appl. Phys. (A)* 67 (1998) 1.
- [8] G.N. Zhizhin, S.A. Voronov, G. Shirmer, V.A. Yakovlev, *Opt. Spectrosc.* 67 (1989) 375.
- [9] G.N. Zhizhin, K.T. Antonova, V.A. Yakovlev, I. Koprinarov, L. Spasov, G. Grigorov, I. Martev, E.V. Alieva, L.A. Kuzik, A.A. Sigarev, *Vibr. Spectrosc.* 1/2 (1990) 219.
- [10] Yu.E. Petrov, E.V. Alieva, G.N. Zhizhin, V.A. Yakovlev, *Zhurnal Tekhnicheskoi Fiziki* 68 (1998) 64 (in Russian).
- [11] G.N. Zhizhin, A.A. Sigarev, V.A. Yakovlev, *J. Mol. Liq.* 53 (1992) 1.
- [12] V.I. Silin, Yu.Yu. Kulis, G.N. Zhizhin, V.A. Yakovlev, *Biophysics* 35 (1990) 55.
- [13] V.V. Vaichikauskas, E.K. Maldutis, V.I. Silin, V.A. Yakovlev, G.N. Zhizhin, *Intern. J. Infrared Millimeter Waves* 12 (1991) 1233.
- [14] V.V. Vaichikauskas, E.K. Maldutis, G.N. Zhizhin, V.A. Yakovlev, *Pis'ma v Zhurnal Tekhnicheskoi Fiziki* 16 (1990) 62 (in Russian).
- [15] G.N. Zhizhin, A.K. Nikitin, G.D. Bogomolov, V.V. Zavalov, J.Y. Uk, L.B. Cheol, S.H. Park, H.J. Cha, *Opt. Spectrosc.* 100 (2006) 734.
- [16] R.J. Bell, *Introductory Fourier Transform Spectroscopy*, Academic Press, 1972.
- [17] G.N. Zhizhin, V.A. Vaguine, *Main stages of fourier-spectroscopy development*, in: K.I. Tarasov (Ed.), *High-Apperture Spectral Instruments*, Moscow, 1988.
- [18] G.N. Zhizhin, F. Parker, M.A. Chesters, V.A. Yakovlev, *Opt. Spectrosc.* 65 (1988) 223.
- [19] E. Titchmarsh, *Introduction to Fourier Integrals Theory*, Moscow-Leningrad, 1948.
- [20] A.P. Kiryanov, *Fourier-interferometry of ortoferrites in far infrared*, in: *Systems of Peculiar Temperature Point in Solids*, Moscow, 1986.
- [21] A.A. Kcharkevich, *Spectra and Analysis*, Moscow, 1957.