

Application of Holographic Interferometry to Optical Monitoring of Solid Surfaces

G. N. Zhizhin, A. K. Nikitin*, T. A. Ryzhova, and A. P. Loginov

Scientific-Technological Center for Unique Instrument Building, Russian Academy of Sciences, Moscow, Russia

Russian University of Peoples Friendship, Moscow, Russia

e-mail: alnikitin@sci.pfu.edu.ru

Received April 26, 2004

Abstract—A new optical method is proposed for probing transition layers on solid surfaces, which combines high precision inherent in holographic interferometry and high sensitivity characteristic of the optical microscopy using surface electromagnetic waves. The proposed technique has been numerically modeled for monochromatic radiation in the visible spectral range. © 2004 MAIK “Nauka/Interperiodica”.

Introduction. Holographic interferometry is widely used for the investigation of rapid processes in bulk samples [1]. The main advantage of this method in comparison to the classical interferometry is the completely differential character of recording of the wave front distortions. This feature is related to the fact that the classical method is based on the interference of spatially separated light waves existing at the same instant of time, while the holographic technique employs the interference of waves traveling over the same path in different periods of time. Owing to this circumstance, holographic interferometry detects only the wave front distortions caused by the introduction of an investigated object in the path of the wave, while the distortions introduced by elements of the interferometer circuit or by the viewports are not reflected by the differential interferogram, since these distortions are present in both interfering light waves. Using the differential character of the holographic interferometry, it is possible to increase the accuracy of measurements and reduce the level of requirements to the quality of optical elements and their stability in the course of experiments.

The aim of holographic interferometry measurements usually consists in obtaining information about small variations of the volumetric properties of an object. This information is contained in the interference pattern superimposed on the virtual image of the object formed by the scene wave. Visual observation of the interference patterns restricts the accuracy of such measurements to half of the bandwidth, while photographic registration improves this parameter five to ten times.

There were attempts to apply holographic interferometry to the study of microscopic deformations in solids and physicochemical processes on solid surfaces [2, 3]. However, it was established that the precision of holographic measurements is insufficient for unambiguous

interpretation of the results for the systems involving transition layers formed on the sample surface.

In this paper, we suggest a new technique for the holographic interferometry of transition layers on solid surfaces, which is based on the excitation of surface electromagnetic waves (SEWs) on a probed surface area [7]. Using the proposed method, it is possible to increase the accuracy of measurements, since the high precision inherent in holographic interferometry is combined with high sensitivity characteristic of the SEW microscopy.

Peculiarities of the photon excitation and detection of SEWs and the use of SEWs in optical microscopy. SEW represents coupled formation of a wave of free charges on a solid surface with negative real part of the permittivity and an inhomogeneous p -polarized electromagnetic wave. The SEW field exponentially decays with the distance on both sides of the surface and in the lateral direction of wave propagation. SEWs are analogous to the Zennecke–Zommerfeld waves in the radio wave range and to Fano modes in the IR range.

The phase velocity of SEWs is lower than the velocity of light in the surrounding medium. For this reason, the photon excitation of these waves in microscopy applications is performed in the attenuated total reflectance (ATR) mode. The excitation of SEWs is accompanied by an increase in the incident wave field intensity (two to three orders of magnitude) and has a resonance character because the sample surface plays the role of open resonator. Since the main part of the energy of the SEW field is transferred in a near-surface region, the characteristics of these waves (propagation range, phase velocity, field distribution) are determined by the properties of the sample surface and a transition layer. Information about the characteristics of SEWs and, hence, about the probed surface, is contained in the reflected radiation. This makes possible the use of

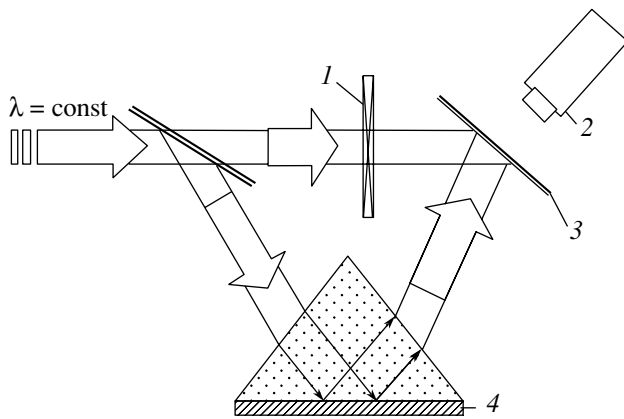

Fig. 1. Schematic diagram of the SEW-phase microscope: (1) controlled attenuator; (2) microscope; (3) screen; (4) sample.

SEWs (called surface plasmons in the case of conducting samples) in all the main optometric techniques [6].

Along with enhancement of the incident wave field, the excitation of SEWs is accompanied by a decrease in the intensity and a jumplike change in the phase of the reflected radiation [4–6]. For this reason, the main methods used to detect the excited SEWs in the reflected radiation are the amplitude and phase techniques.

SEWs have been also effectively used for increasing the sensitivity and vertical resolution of optical microscopy (and holographic interferometry, which is in fact a kind of optical microscopy) [7]. A number of optical microscopy techniques have been developed, which employ the SEWs excited by probing radiation on the sample surface [6]. The names of these techniques usually correspond to the characteristics of reflected radiation used for detecting SEWs.

In the amplitude mode suggested in 1987 by Yeatman and Ash [8], the surface inhomogeneities are detected using variations in the reflected radiation intensity caused by differences in the efficiency of SEW excitation, for example, on clean and contaminated regions of the sample.

In the phase mode of SEW microscopy proposed in 1991 [9], the surface inhomogeneities are detected using variations in the phase of the reflected beam. In this case, the surface inhomogeneities are manifested by curved bands in the interference pattern formed with the aid of a usual optical microscope on a screen and observed in the region of intersection of the reference and reflected beams (Fig. 1). The idea of the SEW-phase microscopy was used for the development of extremely sensitive optical sensors of external actions [10].

The ellipsometric mode [11] employs variations in both intensity and phase of the reflected p -polarized radiation, which provides more complete information about the distribution of inhomogeneities on the sample surface.

The above modes of SEW microscopy are characterized by high vertical resolution (up to fractions of a nanometer) and high sensitivity to external factors, but the accuracy of measurements is insufficiently high. This is related for the most part to a difference of the trajectories of rays in the scene beam reflected from the standard and probed regions of the sample surface. As a result, the inhomogeneities and variations of the parameters of the measuring device reduce the quality of the image.

SEW in holographic interferometry. Obviously, the resonance excitation of SEWs accompanied by considerable enhancement of the incident wave field could not escape notice of the specialists in holography because these features of SEWs can be effectively used in both writing and reading holograms. In 1969, shortly after the first experiments with the excitation and detection of SEWs, Bryngdahl [12] suggested several schemes for writing holographic images using SEWs excited by the reference or scene beams. Using these schemes, it is possible to obtain three-dimensional interferograms in a layer of photoresist deposited above a transparent metal film on a flat glass plate. While writing a hologram, the entire free surface of the plate is brought into optical contact (via immersion liquid) with an ATR prism through which SEWs are excited in the metal film by one (reference or scene) of the light beams. The use of SEWs in writing and reading holograms offers the following advantages [12]: (i) it is possible to obtain very thin flat holograms with a thickness determined by the SEW penetration depth in the photoresist ($\sim 1 \mu\text{m}$); (ii) the resonance character of the SEW excitation (with respect to the incidence angle θ and the radiation frequency ω) allows reading to be performed by white light, whereby the required θ and ω are automatically selected; (iii) the image can also be reconstructed using a monochromatic light with arbitrary ω , by selecting an appropriate θ value ensuring the excitation of SEWs in the metal film under photoresist.

The ideas of applying SEWs to holography were continuously developed [13, 14], whereby preference was given to using SEWs in the stage of image reconstruction, which provides for the following positive effects: (i) the reconstructing beam used to excite SEWs exhibits total internal reflectance from the prism base and, hence, creates no background interference for an observer monitoring the system from the other side of the prism; (ii) the image brightness and contrast are markedly improved due to an increase in the diffraction efficiency; (iii) this approach can be used for obtaining flat holographic screens using SEWs excited by TM modes of a planar metal–insulator optic fiber.

Our new proposal consists in using holographic interferometry for the investigation of transition layers on solid surfaces by exciting SEWs excited on the sample surface by the scene beam in the stage of hologram writing. However, no one of the schemes suggested previously [12] is not suited for this purpose. The problem

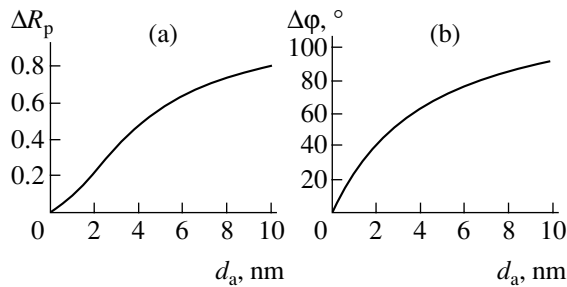

Fig. 2. Calculated curves of the (a) ΔR_p and (b) $\Delta\phi$ versus thickness d_a of a LiF layer on a 45.5-nm-thick copper film, in which SEWs are excited by the radiation with $\lambda = 632.8$ nm via an ATR prism with $n_p = 1.51$.

consists in that both the layer to be studied and the photoresist film have to occur on the same side of the sample surface. However, when photoresist is applied onto the sample (metal film), it blocks access to the surface. Should photoresist be applied onto the film after the transition layer formation, no one of the existing holographic interferometry schemes—neither the real time (RT) technique nor the double exposure (DE) method—can be realized. Therefore, in order to study the transition layer by holographic interferometry, SEWs should be involved in the formation of holograms implicitly, being excited by the scene beam, rather than directly. In this case, a hologram is written essentially in the scheme of SEW-phase microscopy (Fig. 1), in which the holographic plate is used instead of the screen. The recorded hologram can be reconstructed using either SEWs or a bulk wave.

Using the proposed method for writing the hologram of a transition layer, it is possible to compare the interferograms measured in various stages of a process on the sample surface in the RT or DE modes. The new method combines advantages of both the SEW microscopy (high sensitivity and vertical resolution) and the holographic interferometry (completely differential character of writing wave front distortions, basically new level of studying dynamic processes using the RT and DE techniques).

As an example, let us consider the possibility of studying inhomogeneities in a LiF layer (with $n_a = 1.3$) on the surface of a copper film ($n_f = 0.245$, $k_f = 3.50$) by means of the proposed method using an ATR prism with $n_p = 1.51$ and radiation with $\lambda = 632.8$ nm for the SEW excitation in the sample structure. Figure 2 shows calculated curves of the increments in the reflectance (ΔR_p) and phase ($\Delta\phi$) of the p -polarized component versus thickness d_a of the LiF layer. The calculations were

performed for the copper film thickness $d = 45.5$ nm and the incidence angle $\theta = 44^\circ 09'$. Taking into account the measurement accuracy for R_p (to within 1%) and $\Delta\phi$ (to within 10^{-2} rad), we may conclude from the curves of $\Delta R_p(d_a)$ and $\Delta\phi(d_a)$ in Fig. 2 that the method of holographic interferometry with SEW excitation by the scene beam provides for the detection and identification of variations below 1 nm in the LiF layer thickness. According to [7], the sensitivity of ΔR_p and $\Delta\phi$ response to the variations in d_a can be controlled by changing the incidence angle θ or the efficiency of SEW excitation in the stage of hologram writing.

Conclusions. We have proposed a new optical method for probing transition layers on solid surfaces by means of SEWs, which combines the advantages of both the holographic interferometry and the SEW microscopy. The new method has especially good prospects in investigations of the dynamic processes in transition layers on solid surfaces.

REFERENCES

1. C. M. Vest, *Holographic Interferometry* (Wiley, New York, 1979; Mir, Moscow, 1982).
2. R. A. Ashton, D. Slovin, and H. J. Gerritsen, *Appl. Opt.* **10**, 440 (1971).
3. K. N. Petrov and Yu. P. Presnyakov, *Opt. Spektrosk.* **44**, 309 (1978) [*Opt. Spectrosc.* **44**, 179 (1978)].
4. *Surface Polaritons*, Ed. by V. M. Agranovich and D. L. Mills (North-Holland, Amsterdam, 1982; Nauka, Moscow, 1985).
5. M. N. Libenson and I. A. Didenko, *Opt. Vestn.*, No. 5–6, 1 (1992).
6. A. K. Nikitin, Doctoral Dissertation (Scientific-Technological Center for Unique Instrument Building, Russian Academy of Sciences, Moscow, 2002).
7. A. K. Nikitin and T. A. Ryzhova, *Pis'ma Zh. Tekh. Fiz.* **22** (9), 14 (1996) [*Tech. Phys. Lett.* **22**, 347 (1996)].
8. E. M. Yeatman and E. A. Ash, *Electron. Lett.* **23**, 1091 (1987).
9. A. N. Nikitina and A. A. Tishchenko, *Pis'ma Zh. Tekh. Fiz.* **17** (11), 76 (1991) [*Sov. Tech. Phys. Lett.* **17**, 418 (1991)].
10. A. V. Kabashin and P. I. Nikitin, *Kvantovaya Élektron.* (Moscow) **24**, 671 (1997).
11. A. K. Nikitin, *Opt. Zh.* **65** (11), 99 (1998).
12. O. Bryngdahl, *J. Opt. Soc. Am.* **59**, 1645 (1969).
13. J. J. Cowan, *Opt. Commun.* **12**, 373 (1974).
14. S. Maruo, O. Nakamura, and S. Kawata, *Appl. Opt.* **36**, 2343 (1997).

Translated by P. Pozdeev

SPELL: 1. viewports—ok?